

auto electrical parts

Technical Information Sheet

Part No. 0-446-75

Mini xenon beacon, 12 -110 volt dc with polycarbonate amber lens and 2 bolt fixing, 70 flashes per minute. 197 x w 72 x h 132mm. CE and e approved.

Additional Information

The beacon is supplied with flying leads (350mm), 2 fixing bolts (5 x 5mm), nuts and washers, pre-insulated crimp terminals (0.5 - 1.0mm² conductors) and a foam base gasket.



Technical Drawing (not to scale)

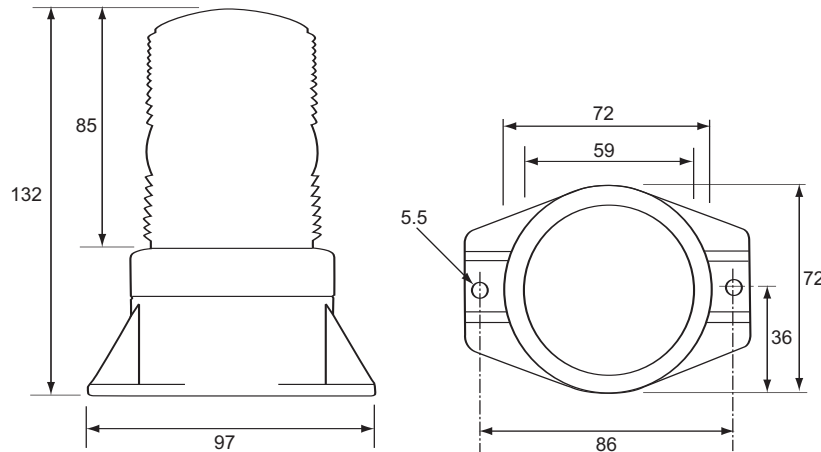

Specification

Type	Mini xenon beacon
Voltage rating	12 - 110 volt dc
Current	0.22 amp @ 12 volt dc
Flash rate	70 single flash per minute
Energy level	1.7 Joules
Lens material	Polycarbonate
Flying leads	350mm
Weight	300g
Dimensions	197 x w 72 x h 132mm (including level and tabs)
Approvals	CE and 'e'
Protection	Waterproof against spray

The information contained in this document is correct to the best of our knowledge at the time of printing. However, specifications may change at any time without notice.